

# FERROVAC GMBH

ULTRA HIGH VACUUM TECHNOLOGY

---

## WM40 Single Shaft Wobblestick DN40CF

### Instruction Manual

---

*Version 1.1*

*05 August 2015*

---

THURGAUERSTR. 72, CH-8050 ZÜRICH, SWITZERLAND  
TEL. +41 44 273 16 38, FAX. +41 44 273 16 30  
[WWW.FERROVAC.COM](http://WWW.FERROVAC.COM), [SALES@FERROVAC.COM](mailto:SALES@FERROVAC.COM)

## ***Warranty***

Ferrovac GmbH warrants this product to be free of defects in material and workmanship for a period of 12 months from the date of shipment.

In case of proof of any defective parts in the product, we will at our option, either repair the product or replace it.

## ***Warranty Limitations***

The warranty for this product does not apply to defects resulting from the following:

- non-observance of operational- and safety instructions
- natural wear of components
- modifications to our products without our written consent
- misuse of any product or part of the product

*This warranty stands in place of all other warranties, implied or expressed, including any warranty of merchantability implied or fitness for a particular use. The remedies provided herein are buyer's sole and exclusive remedies.*

*Neither the company Ferrovac GmbH nor any of its employees shall be liable for any direct, indirect, incidental, consequential or special damages arising out of the use of its products, even if the company Ferrovac GmbH has been advised in advance of the possibility of such damages. Such excluded damages shall include but are not limited to: Costs of removal and installation, losses sustained as the result of injury to any person, or damage to property.*

## ***Copyright***

Copyright 2014, Ferrovac GmbH. All rights reserved. All information in this document is the sole property of Ferrovac GmbH and is protected by Swiss copyright laws and international conventions.

Ferrovac GmbH grants the right for reproduction for the purchasers own use. No part of this manual may be reproduced or transmitted by any third party in any form or by any means and for any purpose without the written permission of Ferrovac GmbH.

# Content

<b>WARRANTY</b>	<b>2</b>
<b>WARRANTY LIMITATIONS</b>	<b>2</b>
<b>COPYRIGHT</b>	<b>2</b>
<b>CONTENT</b>	<b>3</b>
<b>TERMS AND SYMBOLS</b>	<b>4</b>
<b>NORMAL USE</b>	<b>4</b>
<b>1. INTRODUCTION</b>	<b>5</b>
<b>2. UNPACKING AND INSPECTION</b>	<b>5</b>
<b>3. OVERVIEW</b>	<b>6</b>
3.1 NOMENCLATURE	6
3.2 HANDLING	7
<b>4. SETUP AND INSTALLATION</b>	<b>8</b>
4.1 DEFLECTION	8
4.2 MOUNTING	8
4.3 TUBE SUPPORT	9
4.4 BAKEOUT	10
<b>5. ACCESSORIES</b>	<b>10</b>
5.1 FORKS AND HEX ACCESSORIES	10
5.2 HIGH TORQUE MAGNET MKSHT	11
5.3 BELLOWS PROTECTION BP40	12
5.4 WOBBLESTICK ALIGNER TSWMA	12
<b>6 PROBLEM SOLVING</b>	<b>12</b>
6.1 ALIGNING THE MAGNETS	13
6.2 BEARING REPLACEMENT WITH SERWM40(S7)/SERWM40(S5)	14
6.3 FACTORY OVERHAUL	15
6.4 DECLARATION OF DECONTAMINATION	15
6.5 DOWNLOAD	16

## Terms and Symbols

The information in this document represents the state of the product at the date of print. Technical changes may be made without notice. Ferrovac GmbH makes no warranties or representations with respect to accuracy or completeness of the contents of this publication. Figures and photos are not binding. The used product names are for identification purposes and may be trademarks of their respective companies.



A triangle with explanation mark indicates a passage in the manual with information that is crucial for the operator. **READ THESE PARAGRAPHS CAREFULLY** or the product might be damaged by misuse.

### **CAUTION!**

The **CAUTION** heading in a manual explains hazardous situations that could damage the product. Such damage may invalidate warranty.

## Normal Use

The product described in this manual must always be used:

- With original accessories supplied by Ferrovac which are explicitly specified for the use with the product described in this publication.
- In an indoor research laboratory environment.
- By personnel qualified for operation of delicate scientific equipment.
- In accordance with this and all related manuals.



**CAREFULLY READ THE SAFETY INFORMATION AND ALL RELEVANT MANUALS BEFORE USING THE PRODUCT AND ANY RELATED INSTRUMENTATION!**

## 1. Introduction

Single shaft wobblestick are particularly designed for delicate and precise manipulations in ultra high vacuum systems. In opposition to customary products, the motion of the shaft is not affected by the difference between atmospheric pressure and ultra high vacuum. Therefore, the shafts of the wobblesticks can be guided by the operator in a smooth and controlled way. In addition to the linear and angular motion, the shaft can be rotated continuously. Accordingly, the WM40 can be used as a screwdriver, for example to tightly lock sample holders in their dedicated position.

## 2. Unpacking and Inspection

WM40 manipulators are shipped clean and ready to use in UHV. Prepare a sufficiently clean workspace and wear surgical gloves when unpacking and inspecting the device. Check for any visible damage of the package, manipulator and accessories. Compare the contents of the package with the delivery note. Any damage or missing items must be reported to Ferrovac **within 48 hours after delivery**.

### CAUTION!

- **Always** use powder-free examination gloves during unpacking to avoid contamination.
- **Please** ensure enough working space for unpacking and inspection.
- **Please** clean the working table/surface and cover it with Aluminium foil or household foil.
- **Never** hit the knife edge nor the bellows.
- **Never** expose the wobblestick to physical shocks (**brittle magnets!!!**).
- **Never** bend the tube nor the shaft.
- **Never** stress the bellows by torsion.

### 3. Overview

An illustrated overview for the WM40 single shaft wobblestick manipulator is given:



Specifications WM40:

- Linear travel [mm]: 100, 150, 200, 250, 300 or customized
- Angular deflection: +/- 20deg
- Linear force: 30N
- Torque: 0.5Nm
- Bakeout temp: 150deg C
- Pressure range: 10E-11 mbar to 1bar
- Fully UHV compatible

Fig 1 WM40-XXXX-YYYY: Single shaft wobblestick manipulator.

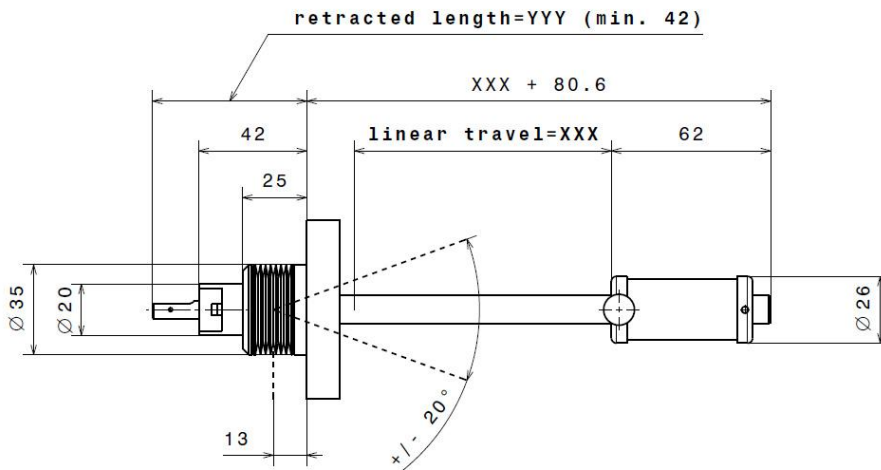

Fig 2 Drawing WM40

#### 3.1 Nomenclature

The main parts of the single shaft wobblestick are named as follows:

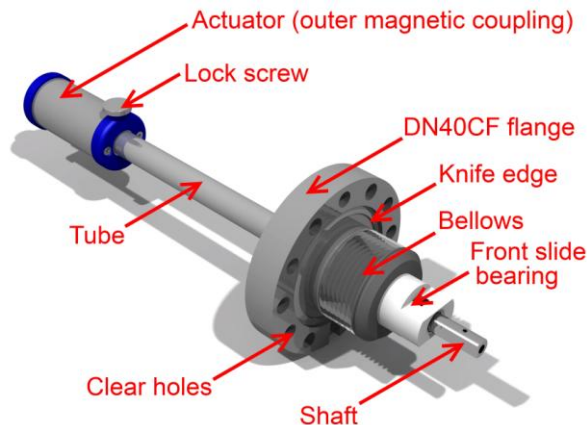

Fig 3 WM40 nomenclature

**CAUTION!**

- **Always** use the tube support parking rail TSWM at any time the wobblestick is not in use.
- **Never** expose the wobblestick to physical shocks (**brittle magnets!!!**).
- **Never** bend the tube nor the shaft.
- **Never** pull the knob off the tube (maximal force is 30N!).
- **Never** overtighten the magnetic coupling in respect to the tube (maximal torque is 0.5Nm!).

### 3.2 Handling

The shaft is magnetically coupled to the actuator: Linear displacement and rotational motion of the actuator causes the same movements of the shaft simultaneously. While linear motion is restricted by natural boundary conditions such as the length of the tube, the shaft can be rotated continuously.

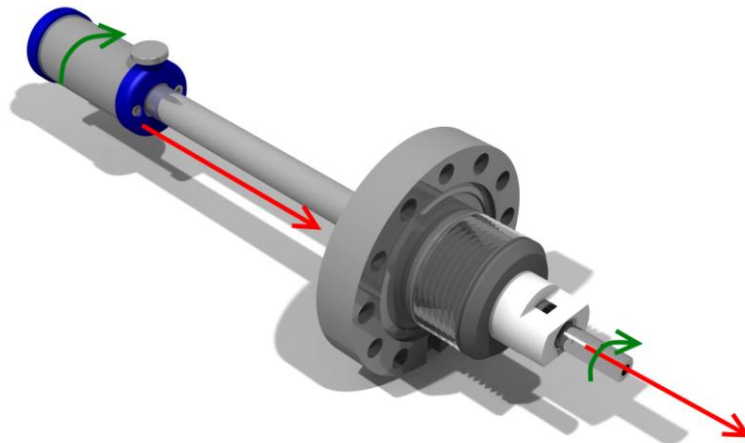

**Fig 4 Handling of the WM40**

- Handling example:
  1. Untighten the lock screw.
  2. Linear motion is realized by pushing (nearly forcefree) the outer magnetic coupling along the red arrow.
  3. While holding the outer magnetic coupling you are allowed to deflect the tube within its maximal angular deflection.
  4. Use a parking rail if provided after the use of the wobblestick and tighten the lock screw.

## 4. Setup and Installation

### 4.1 Deflection

Ferrovac wobblesticks cover two different solid angles. The bellows allow deflections of  $\pm 20^\circ$  on the plane. The "wide angle" WA-wobblesticks have a maximal deflection of  $\pm 28^\circ$  (order-code: WMWA40-XXXX-YYYY).

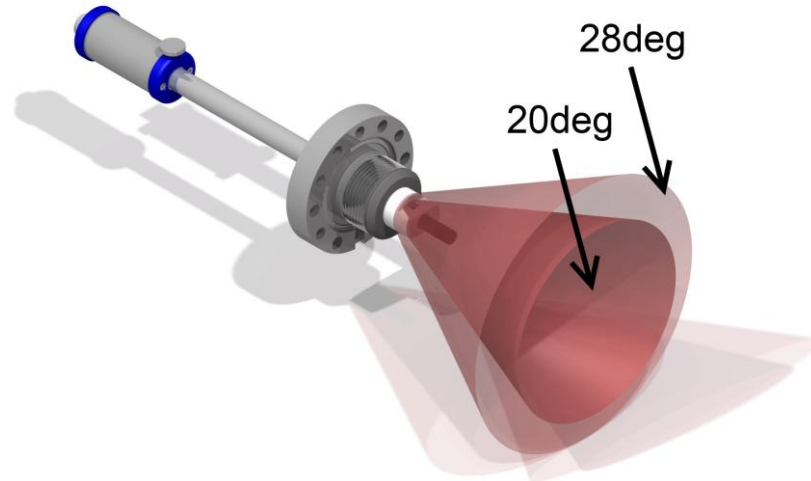

Fig 5 Maximal deflections



**CAUTION:** To prevent the bellows from being damaged, the wobblesticks should be mounted to DN40CF flanges with oversize tubes (see section 4.2).

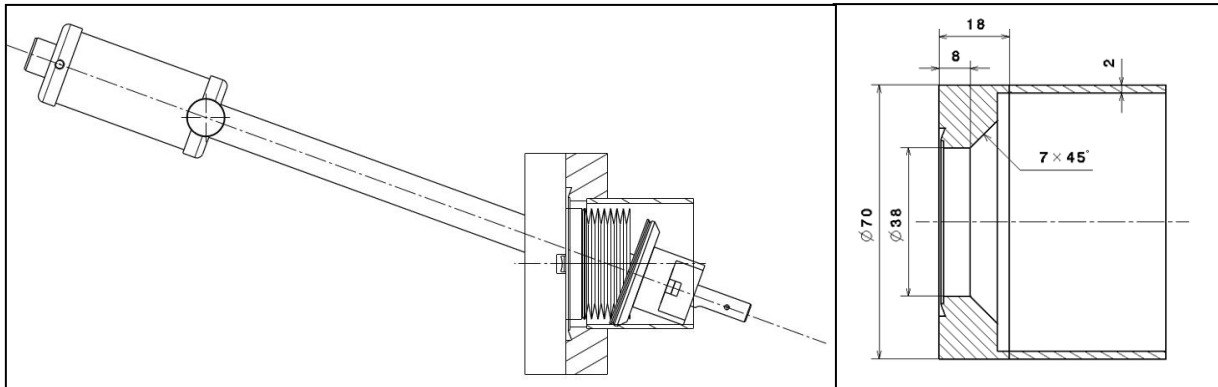

Fig 6 Risk of damaging the wobblestick without oversize tubes

Fig 7 Dimensions of an oversize tube

A normal CF40 flange with an inner diameter of 38mm does, depending on its length, eventually reduce the angular range of the wobblestick. "DN35CF" flanges with an inner diameter of 35mm are not suitable for WM40 and WMG40 wobblesticks. See *section 5.3* for a non-oversize tube solution.

### 4.2 Mounting

In delicate situations, the mounting procedure exposes the wobblestick to the risk of being damaged. Please follow the warning notes and the illustrated instruction.



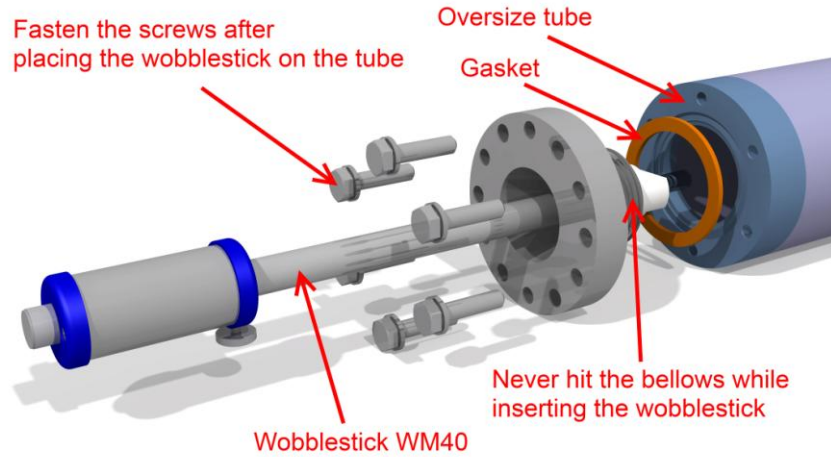

Fig 8 Mounting arrangement, screws used: M6x20 hex-headed or cylindrical

**CAUTION!**

- **Always** use powder-free examination gloves during mounting to avoid contamination.
- **Always** use the tube support parking rail TSWM at any time, the wobblestick is not in use.
- **Never** expose the wobblestick to physical shocks (**brittle magnets!!!**).
- **Never** bend the tube nor the shaft.
- **Never** hit the knife edge nor the bellows.

### 4.3 Tube support

Especially wobblesticks with longer travel ranges require special care to be taken so that the operators do not accidentally bend the tube while the wobblestick is not in use. The support is simply plugged into the flange of the wobblestick and pulled off during manipulation.

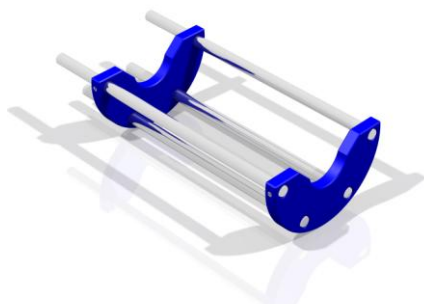

Fig 9 Tube support inline TSWMIL

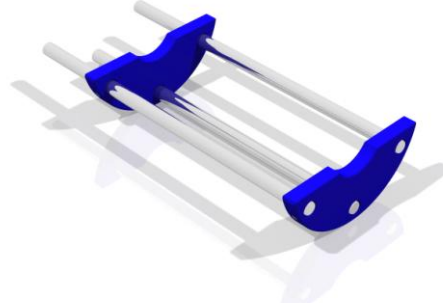

Fig 10 Tube support TSWM



Fig 11 Tube support vertical TSWMV

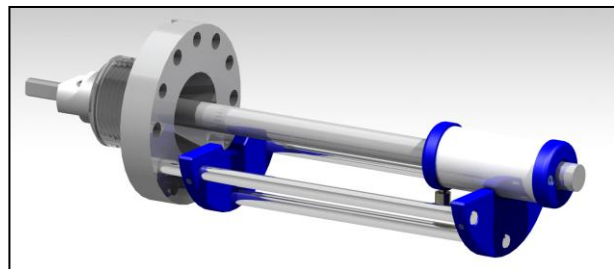



Fig 12 WM40 with TSWM tube support rail

## 4.4 Bakeout

All Ferrovac manipulators are bakeable up to 150°C. Do **not** remove the magnetic coupling for the bakeout procedure. It is recommended to use the parking rail if provided during bakeout. In order to minimize evolution of residual gas, it is helpful to move the coupling back and forth during cooldown of the UHV system after bakeout.



**CAUTION!** Never remove the magnetic coupling for the bakeout procedure.  
Always keep temperature **below 150°C!**

## 5. Accessories

### 5.1 Forks and hex accessories

#### 5.1.1 Straight fork for block style holders FRKBS

This simple sample exchange fork can be used in combination with all WM40 magnetically driven wobblesticks to manipulate block style sample holders SHBS or SHBS(5).

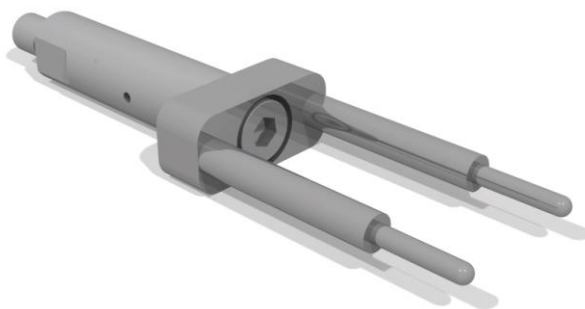

Fig 13 FRKBS

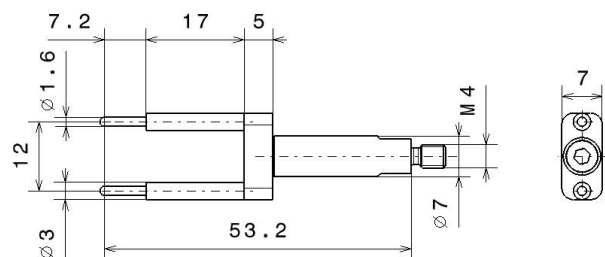

Fig 14 Dimensions FRKBS

#### 5.1.2 Short fork for block style holders FRKBSDM

A short version of the straight fork for block style holders. The FRKBS without D=7mm shaft.

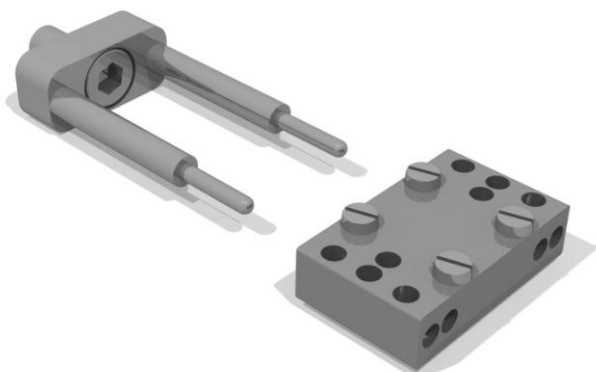

Fig 15 FRKBSDM

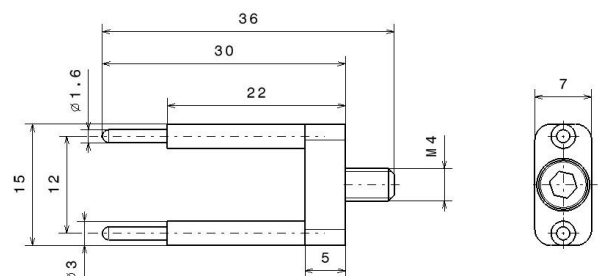

Fig 16 Dimensions FRKBSDM

### 5.1.3 Hex key

This key can be used in combination with WM40/WMWA40 wobblesticks for tightening/loosening in-vacuum hexagonal socket screws. Available in both, metric and imperial type hex keys. Please specify key type and size upon ordering.

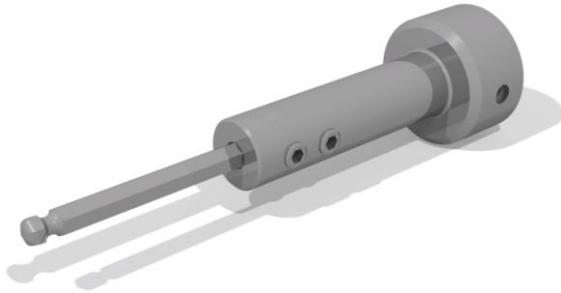

Fig 17 HEXKEY

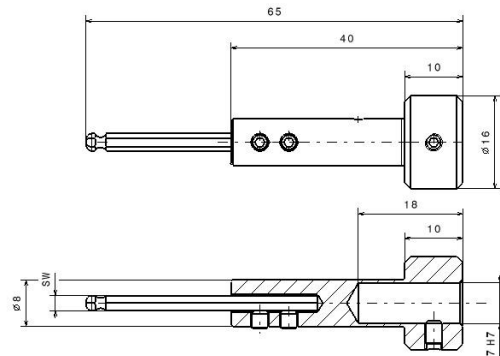

Fig 18 Dimensions HEXKEY

### 5.1.4 Hex nut

Turns your wobblestick into an allen wrench. Used in combination with WM40/WMWA40 wobblesticks for tightening/loosening in-vacuum hexagonal head screws. Available in both, metric and imperial sizes. Please specify nut type and size upon ordering.

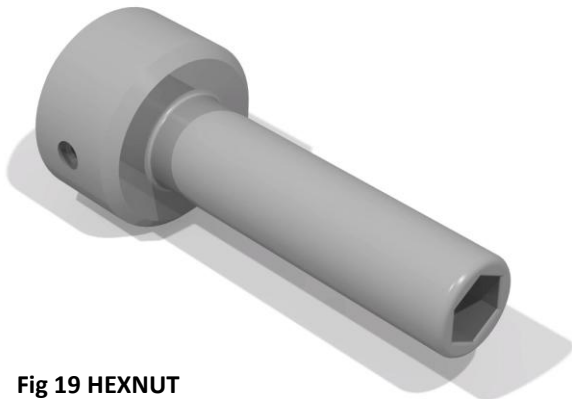

Fig 19 HEXNUT

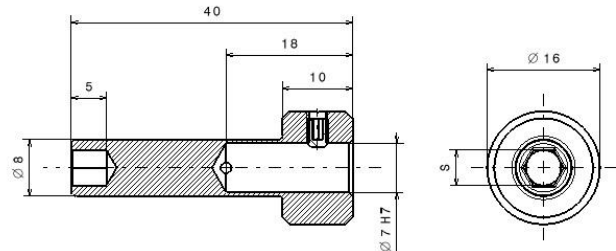

Fig 20 Dimensions HEXNUT

## 5.2 High torque magnet MKSHT

The MKSHT is a longer actuator for single shaft manipulators (WM, MD, RD). A high torque of 1Nm (140 in.oz) optimizes torsional applications like using the manipulator as a screwdriver.

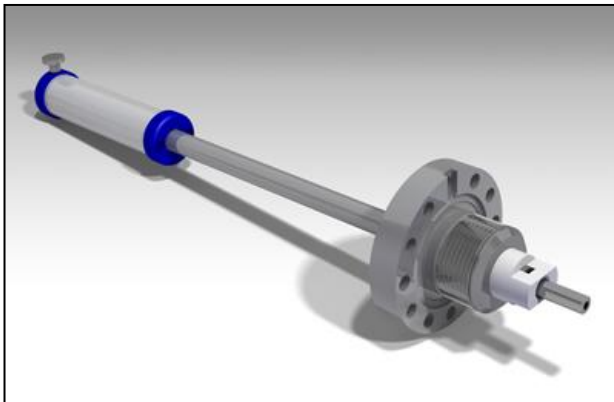

Fig 21 WM40HT: single shaft wobblestick with MKSHT

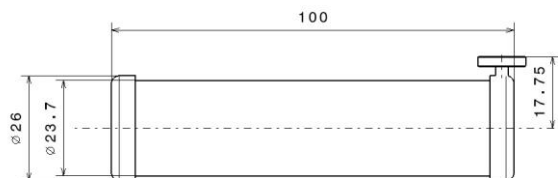

Fig 22 Dimensions MKSHT

### 5.3 Bellows protection BP40

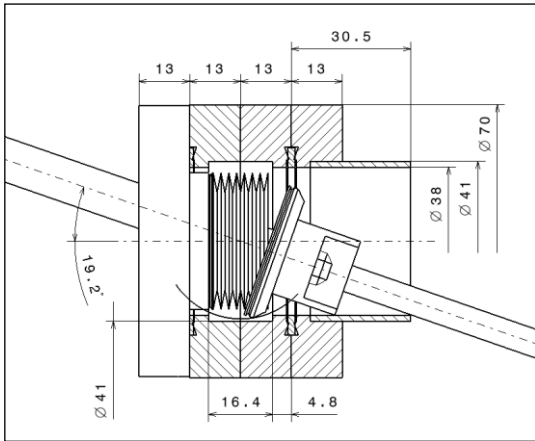

Fig 23 Bellows protection BP40

In case no oversize tube is available, the BP40 protects the bellows from being damaged. Due to the smaller inner diameter, the maximal deflection reduces, depending on the length of the tube. To align the wobblestick we recommend the TSWMA.

### 5.4 Wobblestick Aligner TSWMA

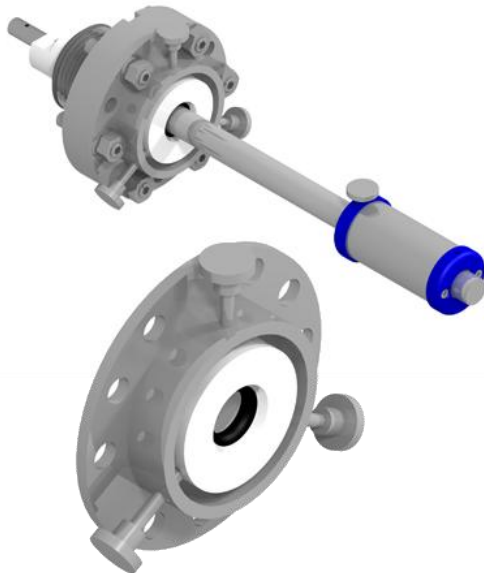

Fig 24 Wobblestick aligner TSWMA

The purpose of the TSWMA is to align the wobblestick as if a port aligner is used. The alignment covers an angle of +/- 4.5 degrees by turning the three knurled screws.

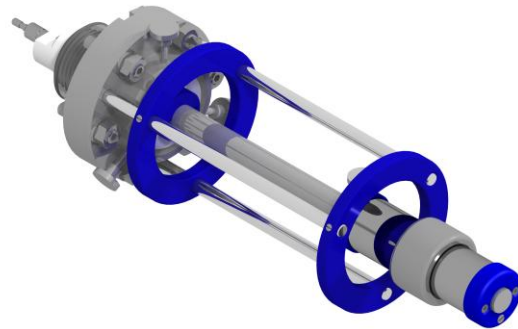

Fig 25 Aligner with external support rail TSWMF

## 6 Problem solving

Please follow the warning notes for this whole chapter:

#### CAUTION!

- **Always** use powder-free examination gloves to avoid contamination.
- **Please** ensure enough working space for inspection.
- **Please** clean the working table/surface and cover it with Aluminium foil or household foil.
- **Never** hit the knife edge nor the bellows.
- **Never** expose the wobblestick to physical shocks (**brittle magnets!!!**).
- **Never** bend the tube nor the shaft.
- **Never** stress the bellows by torsion.

## 6.1 Aligning the magnets



**WARNING:** If you decide to reposition the outer magnetic coupling yourself, Ferrovac GmbH can of course not take any responsibility for damage caused to or by the wobblestick or by your related actions.

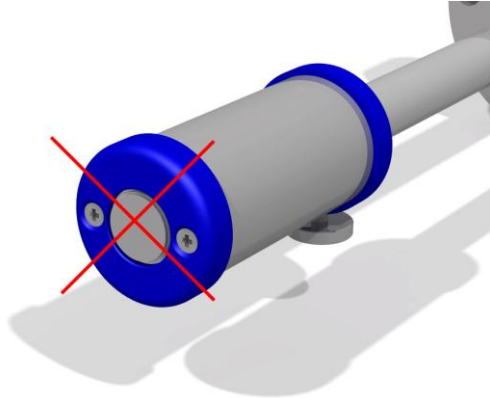

Fig 26 Wrong alignment (fully retracted)

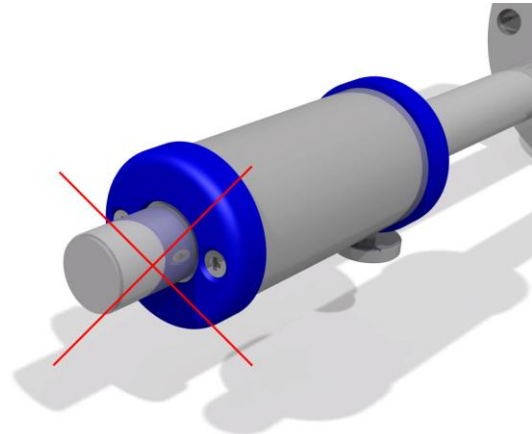

Fig 27 Wrong alignment (fully retracted)

If the specified linear force of 30N is exceeded during use of a wobblestick (outer magnets in respect to the inner magnets), the magnets are displaced in respect to each other. Each inner and outer magnet assembly is built with several rows of counterwise poled magnets. When both halves are in their proper place, the rear of the tube stands out approximately 7mm.

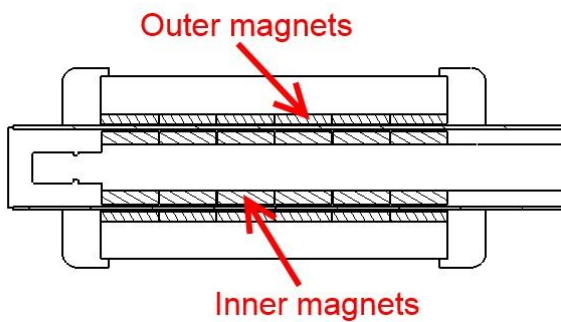

Fig 28 Inner/Outer magnets, correct alignment

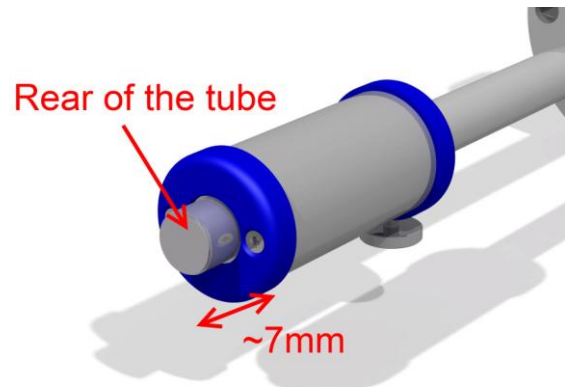

Fig 29 Correct alignment (fully retracted)

**Repositioning the magnet assembly (wobblestick dismantled from vented system):**

- Pull the outer magnetic coupling off the tube.
- With a gloved hand, hold the shaft of the wobblestick firmly.
- With the other hand, start pushing the outer magnetic coupling onto the tube. Every time a row of outer magnets is pushed over an inner one, a strong 'click' can be felt when they lock.
- While moving linearly, the magnets will want to rotate 1/8th of a full turn for every row of magnets (due to the eight-fold symmetry of the magnets), which can be felt. So it is beneficial to push linearly and simultaneously turn a little.

**Repositioning the magnet assembly\* without venting:**

- Put one thumb on the end of the tube and two fingers around the actuator.
- Pull back until the outer magnet coupling is positioned as shown in figure 29.
- Should the magnet assembly move too far off the back of the tube:
  - Find something rigid inside your chamber to press against.

**Be very careful** when pushing against any part inside your UHV system!

**6.2 Bearing replacement with SERWM40(S7)/SERWM40(S5)**

The slide bearings are the only parts of the wobblestick that wear out. It is important to check the smoothness of the motion from time to time and please make sure, you don't hear any scratching noise or feel unusual friction while using the wobblestick. Worn out bearings can be responsible for extensive outgassing effects during motion. If any of the above occurs, replace the bearings. We offer service kits for wobblesticks with shaft OD=7mm: SERWM40(S7) as such for wobblesticks with shaft OD=5mm (mostly older WM40 models): SERWM40(S5).

**CAUTION!**

- **Always** use powder-free examination gloves to avoid contamination.
- **Please** ensure enough working space for inspection.
- **Please** clean the working table/surface and cover it with Aluminium foil or household foil.

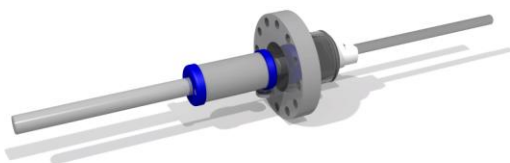

**Fig 30** Extract the shaft fully.



**Fig 31** Hold the shaft with one hand, pull off the actuator with the other.



**Fig 32** Remove the front slide bearing by turning it counterclockwise.

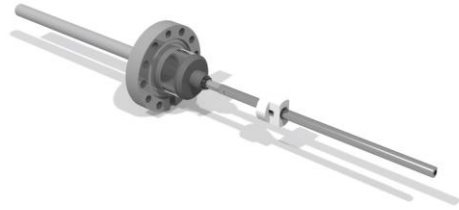

**Fig 33** Remove the shaft carefully: Avoid tilting the shaft axis. Tilting may damage the inner magnet assembly.



**Fig 34** Remove the circlip and replace the inner slide bearing (white) using a suitably small screwdriver.

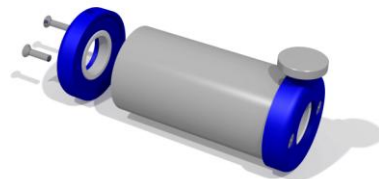

**Fig 35** Remove the crosshead screws on the actuator, replace the outer blue rings with the new ones.

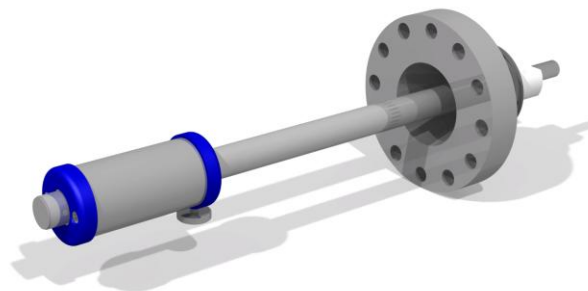

**Fig 36** Follow the instructions of Fig 30 to Fig 33 backwards to reassemble the wobblestick. Refer to chapter 6.1 to align the magnets correctly.

### ***6.3 Factory overhaul***

Though every welded bellows has in theory a limited lifetime, in practice the slide bearings are the only parts of the wobblestick that wear out. Many bakeout periods lead to slight deformation of the slide bearings. This can result disturbances of the motion smoothness and probably higher outgassing rates. We offer an all-over factory overhaul for inner and outer bearings and readjustement. Please have a look on our website for more information or contact us directly.

### ***6.4 Declaration of decontamination***

In case of returning the wobblestick to Ferrovac GmbH, it is necessary to complete a declaration of contamination and send it to us. Please contact us beforehand. An RMA will be issued and mailed to you.

## ***6.5 Download***

This manual can be downloaded from our website. It can be found in the specifications of each listed dual shaft wobblestick manipulator.